



B-CLASS SEA ALFA

TECHNICAL SPECIFICATIONS

GENERAL

Type	Shoalbuster 3009
Classification	Bureau Veritas ⚓ Hull · Mach / Unrestricted
IMO number	9466271
Year built	2008 - Damen Hardinxveld, NL
Flag	Dutch
Port of Registry	Vlissingen
Call sign	PHSA
MMSI	245168000

DIMENSIONS

Length overall	30,08 m
Breadth overall	9,10 m
Minimum draft	2,90 m
Operating draft	3,00 m
Maximum draft	3,20 m
Minimum air draft	10,30 m
Maximum air draft	16,00 m
Gross tonnage	309 t
Net tonnage	92 t

TANK CAPACITY

Fuel oil	174,9 m ³
Fresh water	40,9 m ³
Lubrication oil	7,3 m ³
Hydraulic oil	3,1 m ³
Dirty oil	4,3 m ³
Sewage	3,3 m ³
Bilge water	4,3 m ³

PERFORMANCE

Bollard pull	50,0 t
Maximum speed	11,00 knots
Economic speed	9,00 knots

PROPULSION SYSTEM

Main engines	2x CAT 3512 BTA
Total power	2.462 kW / 3300 bhp
Propulsion	2x Promarine fixed pitch propellor
Bowthruster	250 bhp, hydraulic driven

DECK CRANE

Type	Heila HLRM 140-4SL
Capacity	5,30 t @ 18,03 m

DECK EQUIPMENT

Free deckspace	60,0 m ²
Deck strenght	5,0 t/m ²
Towing winch	Ridderinkhof Waterfall 50 t / 100 t (pull/hold) 750 m x 44 mm
Anchor handling winch	100 t / 100 t (pull/hold) 600 m x 40 mm
Tugger winch	8 t
Towing pins	3-in row SWL 100 t
Pushbow	Full length rubber fendered
Stern roller	SWL 50 t

AUXILIARY EQUIPMENT

Main generator sets	2x John Deere 6068 T
Fuel oil transfer pump	50 m ³ /h @ 4,8 bar
Fresh water transfer pump	50 m ³ /h @ 4,8 bar
Fresh water maker	HEM 6 m ³ /24h
Air compressor	ABAC B5900
Powerpack	1x CAT C18 TA

ACCOMMODATION

Persons	7
Single cabin	3
Double cabin	2
Air conditioned	Yes



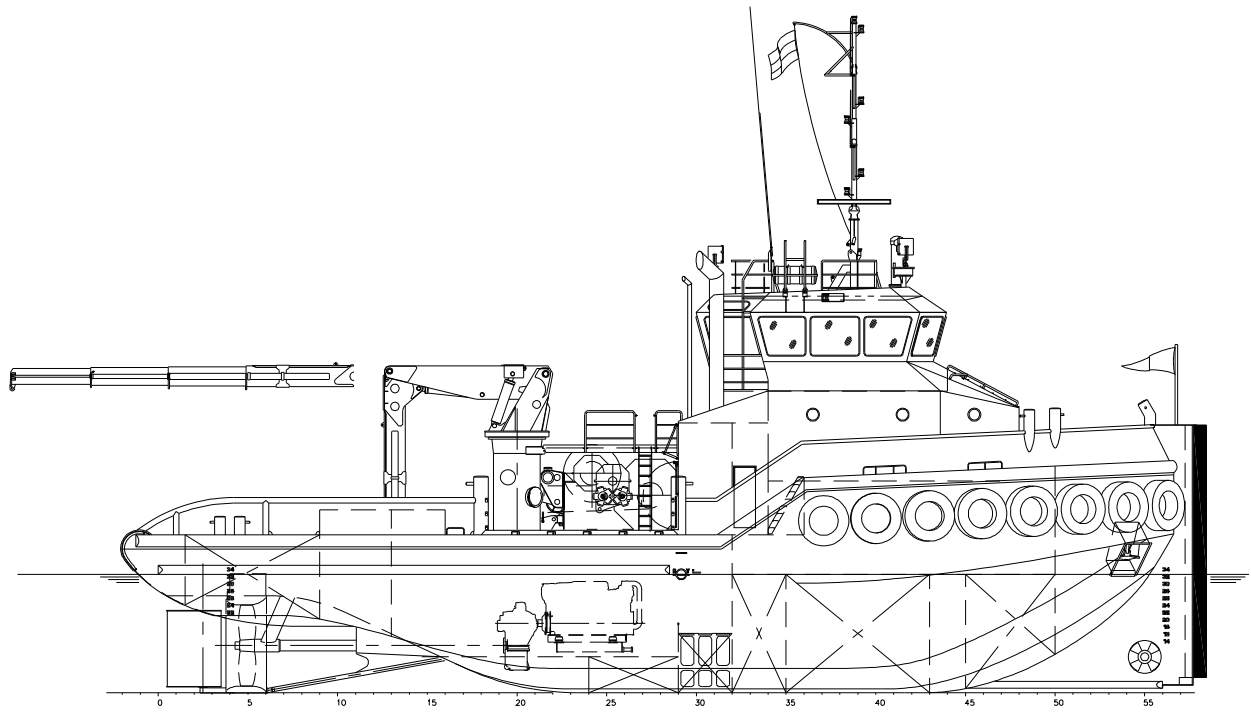

Maindeck

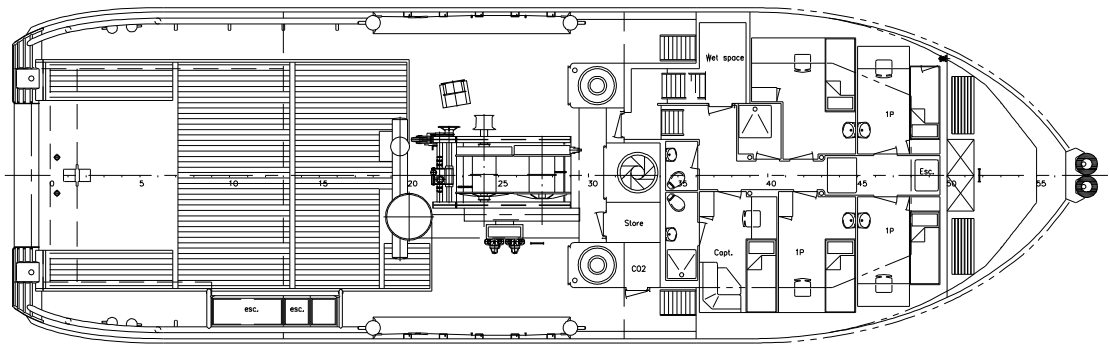

Below maindeck

